

Lubricator

L16 EconOmist™

L17 AtoMist™

= "Most Popular"

Specifications

Flow Capacity*	1/4	36.1 SCFM (17.0 dm ³ /s)
	3/8	58.5 SCFM (27.6 dm ³ /s)
	1/2	64.0 SCFM (30.2 dm ³ /s)
Initial Drip Flow	.38 - 1.37 SCFM	
Maximum Supply Pressure	Plastic Bowl	150 PSIG (10.3 bar)
	Metal Bowl	200 PSIG (13.8 bar)
Minimum Flow for Lubrication	1.4 SCFM @ 100 PSIG	
Operating Temperature	Plastic Bowl	32° to 125°F (0° to 52°C)
	Metal Bowl	32° to 150°F (0° to 65.5°C)
Port Size	NPT / BSPP-G 1/4, 3/8, 1/2	
Bowl Capacity	L16	5.0 oz
	L17	3.4 oz
Weight	1.8 lb. (0.82 kg)	

* Inlet pressure 150 PSIG (10.3 bar). Pressure drop 5 PSID (0.3 bar).

Materials of Construction

Body	Zinc	
Bowls	Plastic Bowl	Polycarbonate
	Metal Bowl	Zinc
Seals	Plastic Bowl	Nitrile
	Metal Bowl	Fluorocarbon
Sight Dome	Polycarbonate	
Sight Gauge	Metal Bowl	Polycarbonate
Suggested Lubricant	Airline Oil F442001	

B

Filters, Regulators, Lubricators



L16 / L17-02-000

Features

- L16 Model Can be Filled with Lubricant while Under Pressure (**L17 AtoMist™ Cannot be Filled Under Pressure**)
- Siphon Tube Filter Provides Clean Lubricant Downstream
- Quick-Disconnect Bowl Guard with Integral Plastic Bowl and Safety Latch
- Adjustable Oil Feed
- Optional Petcock Drain in Polycarbonate Bowl

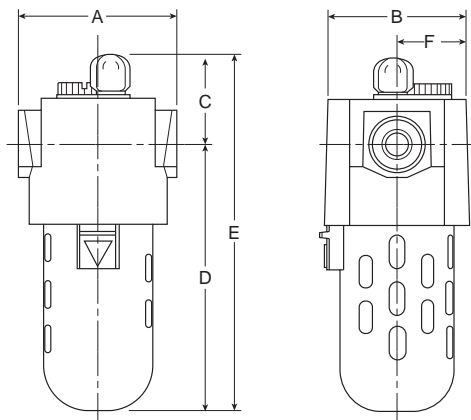

Dimensions

Models	Inches (mm)	A	B	C	D	E	F
Standard Unit L16-XX-000 & L17-XX-000		3.00 (76)	2.62 (66.5)	1.62 (41)	5.03 (128)	6.66 (169)	1.31 (33.3)
Manual Drain L16-XX-D00 & L17-XX-D00		3.00 (76)	2.62 (66.5)	1.62 (41)	5.83 (148)	6.58 (167)	1.31 (33.3)
Metal Bowl with Sight Gauge L16-XX-G00 & L17-XX-G00		3.00 (76)	2.62 (66.5)	1.62 (41)	6.21 (158)	7.80 (198)	1.31 (33.3)

= "Most Popular"

Replacement Bowl Kits

- Metal Bowl with Sight Gauge,
Brass Petcock Drain.....GRP-95-133
- Plastic Bowl –
No Drain Port.....LRP-96-937
- Plastic Petcock DrainLRP-96-543

Replacement Kits

- Fill Plug Kit – Fill Plug and O-ring LRP-95-253
- Flow Guide –
1/4 NPT / BSPP-G , L16..... LRP-95-241
- 3/8 and 1/2 NPT / BSPP-G, L16 LRP-95-242
- 1/4 NPT / BSPP-G , L17 LRP-95-246
- 3/8 and 1/2 NPT / BSPP-G, L17 LRP-95-247
- Sight Dome Kit – Sight Dome and O-ring LRP-95-239
- Tube, Siphon – Tube and Bronze FilterLRP-96-005

Accessories

- Air Line Oil (1 Qt. Bottle)..... F442001
- Low Level SwitchLRP-95-093
- Manual Drain –
Brass Petcock.....GRP-95-182
- Plastic Petcock.....LRP-95-181
- Tamper Resistant Kit.....LRP-95-587
- Wall Mounting Bracket, L-TypeGPA-95-016

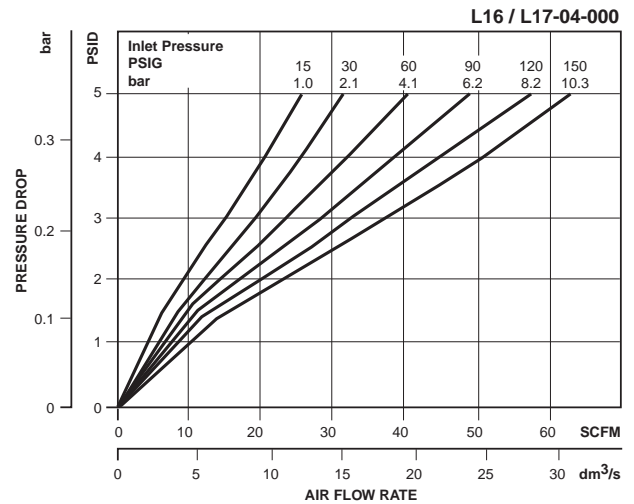
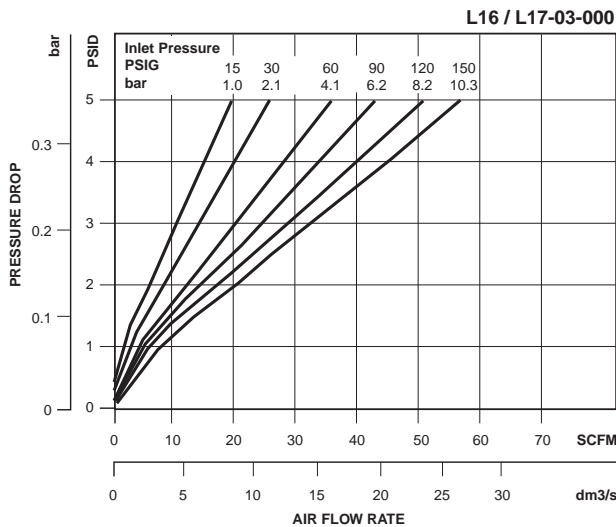
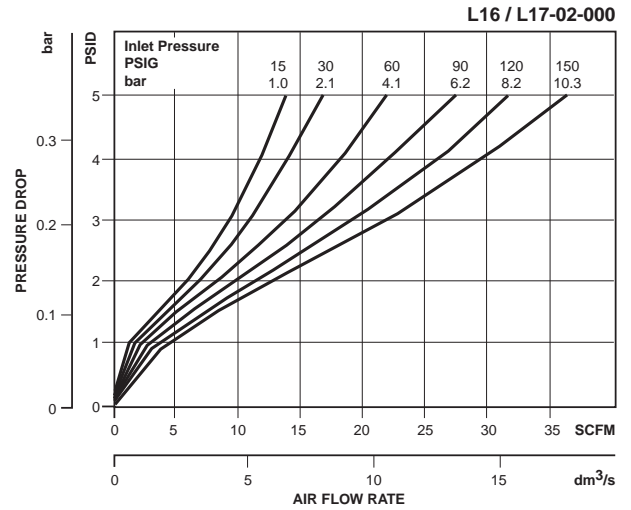

Ordering Information

Model Type	Port Size	Polycarbonate Bowl / Bowl Guard	Polycarbonate Bowl / Bowl Guard with Manual Drain	Metal Bowl / Sight Gauge
EconOmist™	1/4	L16-02-000	L16-02-D00	L16-02-G00
	3/8	L16-03-000	L16-03-D00	L16-03-G00
	1/2	L16-04-000	L16-04-D00	L16-04-G00
AtoMist™	1/4	L17-02-000	L17-02-D00	L17-02-G00
	3/8	L17-03-000	L17-03-D00	L17-03-G00
	1/2	L17-04-000	L17-04-D00	L17-04-G00

Options - To order an option supplied with the unit model, add the appropriate coded suffix letter in the designated position of the model number.