

# Regulator R16

 = "Most Popular"

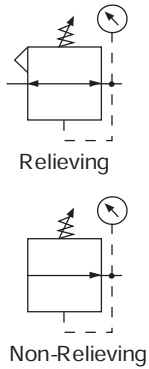

R16-02-000

## Features

- Non-Rising Adjustment Knob with Friction Lock Knob
- Standard with Two Full Flow 1/4" NPT /BSPT-Rc Gauge Ports
- Panel Mount Nut
- High Flow Capacity
- Balanced Valve Design for Excellent Regulation Characteristics

## Specifications

Flow Capacity*	1/4	71.5 SCFM (33.7 dm <sup>3</sup> /s)
	3/8	80.5 SCFM (38.0 dm <sup>3</sup> /s)
	1/2	88.0 SCFM (41.5 dm <sup>3</sup> /s)
Adjusting Range Pressure	0 to 60 PSIG (0 to 4.1 bar)	
	0 to 125 PSIG (0 to 8.6 bar)	
	0 to 250 PSIG (0 to 17.2 bar)	

Maximum Supply Pressure	300 PSIG (20.7 bar)	
Operating Temperature	32° to 150°F (0° to 65.5°C)	
Port Size	NPT /BSPP-G	1/4, 3/8, 1/2
Gauge Port (2 ea.)	NPT /BSPT-Rc	1/4
Weight	lb. (kg)	1.7 (0.77)

\* Inlet pressure 100PSIG (6.9bar). Secondary pressure 90PSIG (6.2bar).

## Materials of Construction

Body	Zinc
Bonnet	PBT
Diaphragm	Nitrile /Zinc
Panel Nut	Acetal
Seals	Nitrile
Springs	Steel
Valve Assembly	Brass /Nitrile /Acetal

### WARNING

**Product rupture can cause serious injury.  
Do not connect regulator to bottled gas.  
Do not exceed maximum primary pressure rating.**

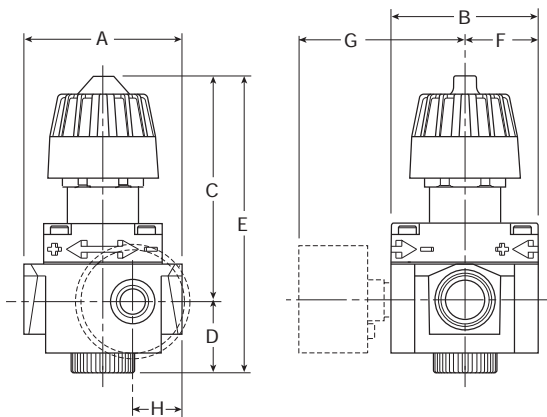

NOTE: 1.31" Dia. (33.3mm) hole required for panel nut mounting.

## Dimensions

Models	Inches (mm)	A	B	C	D	E	F	G	H
Standard Unit R16-XX-000		2.99 (76)	2.59 (66)	3.99 (101.3)	1.20 (30.5)	5.19 (132)	1.29 (33)	—	1.02 (25.9)
With Gauge R16-XX-G00		2.99 (76)	2.59 (66)	3.99 (101.3)	1.20 (30.5)	5.19 (132)	1.29 (33)	2.80 (71)	1.02 (25.9)

## CAUTION:

**REGULATOR PRESSURE ADJUSTMENT** - The working range of knob adjustment is designed to permit outlet pressures within their full range. Pressure adjustment beyond this range is also possible because the knob is not a limiting device. This is a common characteristic of most industrial regulators, and limiting devices may be obtained only by special design.

For best performance, regulated pressure should always be set by increasing the pressure up to the desired setting.

### Replacement Kits

- Adjusting Knob..... RRP-95-023
- Diaphragm Assembly -
  - Non-relieving ..... RRP-96-216
  - Self-relieving..... RRP-96-213
- Spring, Regulating -
  - 0 to 50 PSIG (0 to 3.4 bar)..... RRP-95-222
  - 0 to 125 PSIG (0 to 8.6 bar)..... RRP-95-224
  - 0 to 250 PSIG (0 to 17.2 bar)..... RRP-95-218
- Valve Assembly -
  - Valve, Valve Spring, Bottom Plug O-ring..... RRP-96-215

### Accessories

- Gauge, Pressure -
  - 0 to 60 PSIG (0 to 4 bar), 2" Dial Face, 1/4 NPT, CBM..... K 4520N14060W
  - 0 to 160 PSIG (0 to 11 bar), 2" Dial Face, 1/4 NPT, CBM..... K 4520N14160W
  - 0 to 300 PSIG (0 to 20 bar), 2" Dial Face, 1/4 NPT, CBM..... K 4520N14300W
  - 0 to 160 PSIG, 1-3/4" Digital Round ..... K 4517N14160D
- Panel Mount Nut, Plastic ..... GPA-95-032
- Tamper Resistant Kit, Ring Style..... RPA-95-006
- Wall Mounting Bracket, Gauge Port Adapter, 1/4 NPT ..... RRP-95-590
- Wall Mounting Bracket-
  - L-Type, Heavy Duty ..... RPA-95-090
  - L-Type, Standard..... GPA-95-012
  - L-Type with Plastic Panel Mount Nut..... GPA-95-011

= "Most Popular"

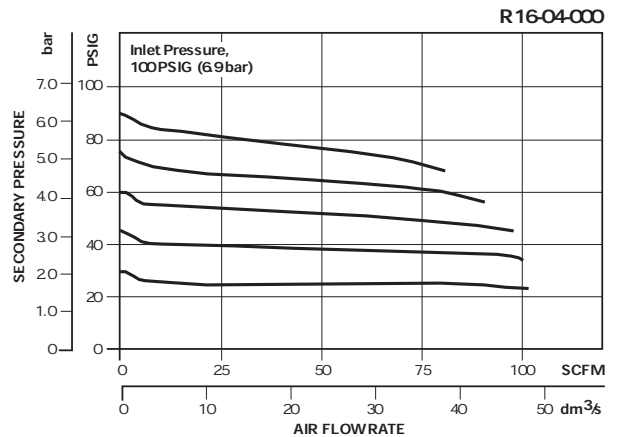
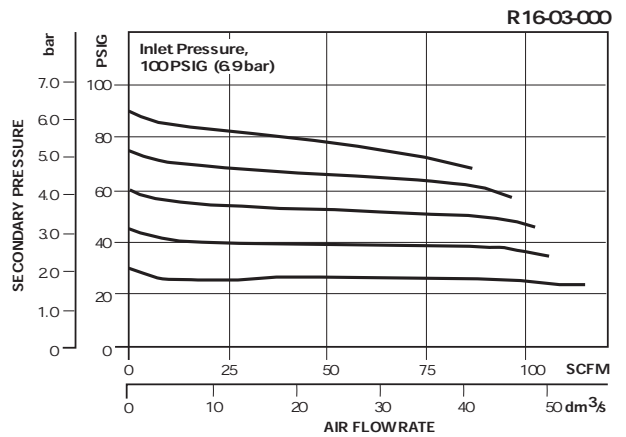
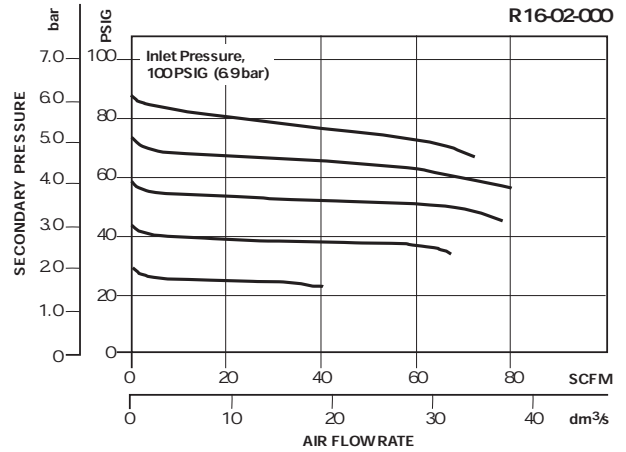

### Ordering Information

Model Type	Port Size	Without Gauge 5 to 125 PSIG (0.4 to 8.6 bar)	Without Gauge 10 to 250 PSIG (0.7 to 17.2 bar)	Without Gauge 3 to 60 PSIG (0.2 to 4.1 bar)	With Gauge 5 to 125 PSIG (0.4 to 8.6 bar)	With Gauge 10 to 250 PSIG (0.7 to 17.2 bar)	With Gauge 3 to 60 PSIG (0.2 to 4.1 bar)
Relieving	1/4	R16-02-000	R16-02-H00	R16-02-L00	R16-02-G00	R16-02-GH0	R16-02-GL0
	3/8	R16-03-000	R16-03-H00	R16-03-L00	R16-03-G00	R16-03-GH0	R16-03-GL0
	1/2	R16-04-000	R16-04-H00	R16-04-L00	R16-04-G00	R16-04-GH0	R16-04-GL0
Non-relieving	1/4	R16-02-N00	R16-02-HN0	R16-02-LN0	R16-02-GN0	R16-02-GHN	R16-02-GLN
	3/8	R16-03-N00	R16-03-HN0	R16-03-LN0	R16-03-GN0	R16-03-GHN	R16-03-GLN
	1/2	R16-04-N00	R16-04-HN0	R16-04-LN0	R16-04-GN0	R16-04-GHN	R16-04-GLN

Options - To order an option supplied with the unit model, add the appropriate coded suffix letter in the designated position of the model number.